

# OMNIDEKA<sup>e</sup>

## LOW VOLTAGE, HIGH-LEVEL ELECTRIC AUTOMATIC BIN LIFT

The OmniDEKA<sup>e</sup>, a low voltage, high level electric bin lift comes with the expected robust build, safe operation and efficiency synonymous with the Terberg brand to provide the market with the best automatic high-level bin lift solution available today. The OmniDEKA<sup>e</sup> requires only a 24v chassis for operation and has a host of efficiency saving features.



### REASONS TO CHOOSE THE OMNIDEKA<sup>e</sup>:

- OmniDEKA<sup>e</sup> offers great flexibility with mounting heights to suit a variety of applications from 1150mm to 1675mm
- OmniDEKA<sup>e</sup> provides ultra-strong lifting power for two-wheeled bins of 170kg and up to 500kg for four-wheeled bins
- The modern design of the OmniDEKA<sup>e</sup> includes large side windows for maximum visibility and increased safety during operation
- Amazingly light, the OmniDEKA<sup>e</sup> weighs just 680kg (without DIN pick up arms)
- Cycle time for two-wheeled EN840-1 containers is six-seven seconds whilst OmniDEKA<sup>e</sup> will lift, discharge and return a four-wheeled EN840-2 or -3 container in 10-12 seconds
- Short rear overhang projection of just 800mm which increases to 1130mm with the drop down safety arms deployed
- Superbly steep container discharge angle of 46 degrees to reduce the risk of non-emptying bins
- Universal mounting according to EN 1501-1
- 6 per cent more room on the footboards when compared to previous models
- OmniDEKA<sup>e</sup> dynamic split catcher bar operates automatically as required and moves back to its original position following container discharge
- The user friendly folding safety arms conform to EN1501-1 standard and provides guarding against entry into the functional working space during bin lift operation
- Ground clearance of  $\pm 450$ mm
- Kinetic energy is stored during the lifting cycle to provide an energy free chair return under gravity, which in turn reduces noise, saves energy and keeps wear and tear to a minimum
- Single point greasing
- Optional service modem possible
- Designed with weighing in mind. Smooth operation minimises 'bin bounce' and a vertical initial lift providing a 'window' for ease of data recording
- Featuring BCCU, a cleaning mode switch, and two emergency stop buttons per side as standard
- The Bin Compaction Control Upgrade (BCCU) ensures automatic movement stops if cycle start sensors or the container security are compromised, while the cleaning mode allows safe container cleaning

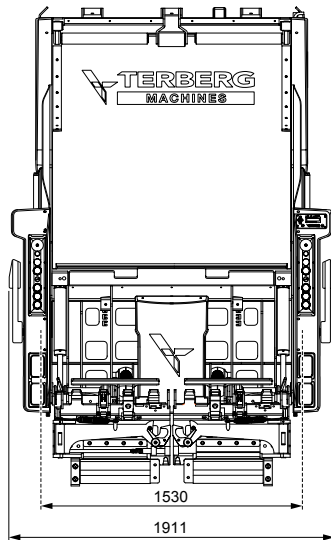

A	B
1200	528
1300	528
1400	528
1500	528
1600	578

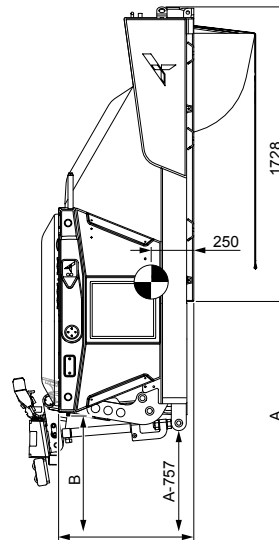

## TECHNICAL SPECIFICATION



EN 840-1 | 80-360L

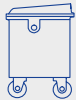

EN 840-2 | 500-1280 L



EN 840-3 | 770-1100 L

### Chair configuration

#### Single Man Trade (SMT)

Pick up arms for bins according to EN 840-2/-3 with trunnions

#### Rear Protective Device (RPD)

#### 4-wheeled recognition

#### Bin Compaction Control Upgrade (BCCU)

#### Diagnostic display

#### Mechanical / Sonar N1 switch

#### Shaking

#### Terberg Weighing & RFID preparation

#### CleanOpen CANbus output

#### Packer Cycle Delay Control (PCDC)

#### Lifting capacity

#### Bin lift weight

#### Power source

#### Electrical connections

#### Chassis battery requirement

#### Chassis alternator requirement

#### Ingress Protection rating

#### Cycle time

#### Noise level

#### Safety and norm compliance

### Split twin chairs

Standard

Option

Standard

Standard

Standard

Standard

Standard

Option

Standard

Option

Standard

Standard

170kg (split) / 500kg (linked)

ca. 650kg

electric

16-pin / 24v

175 Ah minimum, ideal 245Ah (for hybrid chassis please consult Terberg)

Requires 20A spare capacity. Minimum 75A, 100A recommended

Proximity switches/sensors to IP68, "Plug and play" wiring to IP69K

2 wheel 6-7s(= dwell 0.5-1.5)/4 wheel ±10-12s

< 57 dB(A)

CE machinery directive certification EN 1501-1 & EN 1505-5



TERBERG ENVIRONMENTAL

Newtonstraat 2, 3401JA. IJsselstein, The Netherlands

T +44 (0)1925 458 500, E info@terbergenvironmental.com, I www.terbergenvironmental.com

Terberg Environmental reserve the right to change the specification or design of our equipment at any time without prior notification.