

OLYMPUS ART

FOR GLOBAL MARKETS



Olympus ART is specifically developed for operation in countries globally. With proven service in Asia, Africa, GCC, and LATAM markets; coupled with one of our bin lifts Olympus ART changes perceptions of waste collection around the world.

Available in 2.5m and 2.2m wide variants, high compaction rate and wide-ranging configurations, Olympus ART offers exceptional value, solid performance, robust build, and comprehensive aftermarket support via our worldwide distributor network.

ADVANTAGES OF OLYMPUS ART

Designed to meet operational requirements around the world.

Wide range of models: available in two widths, two heights and two hopper sizes.

It may be **adapted to a wide variety of applications and functions.**

For use with our **own bin-lift** technology or adapted for other commercial bin-lift.

Easy maintenance characterised by low maintenance costs.

Robust design: control elements based on Simple Relay Logic systems, with control packing system mechanism accessed from the cab.

High compaction ratios: up to 7:1.

Now with 20% reduction in compaction cycle time: delivering increased productivity.

Keel shaped floor for improved body strength and better leachate drainage via integral sump

Only 2 greasing points to simplify maintenance.

Large capacity tailgate/hopper with a large swept volume.

Hardox tailgate sides and hopper floor for resistance to wear and low cost of ownership.

Hydraulic tank filling coupling point on the body side - Cleaner and easier filling while minimising risk of introducing contaminants.

External Cylinders reduce the risk of damage during tailgate and packer operation. Now with increased efficiency delivering reduced power consumption & more productivity.



BIN LIFT SYSTEMS



MOC 500 ART

Multi-purpose bin-lift for bins and containers specially designed for domestic waste collection. The bin lift is manually controlled by means of levers. Optionally, it can be electrically operated and has a lifting capacity of 500kg.

MOC 500 ART is designed for handling EN-840 standard containers.



MOC ART with skip arms

Industrial container bin-lift using hooks and chains with manual operation by means of levers. It is compatible with MOC 500 ART bin-lift for bins and containers, and it is specially designed for the simultaneous collection of industrial and domestic waste. Lifting capacity for industrial containers is 3500kg. Compatible with a large range of industrial containers.



MOC 800 ART

Multi-purpose bin-lift for bins and containers specially designed for domestic waste collection. The bin lift is manually controlled by means of levers. Optionally, it can be electrically operated and has a lifting capacity of 800kg.

MOC 800 ART is designed for handling EN-840 standard containers. A set of DIN type arms are included for handling EN840-2/3 containers.

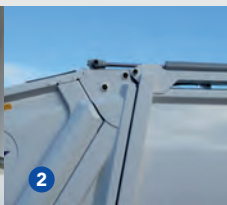
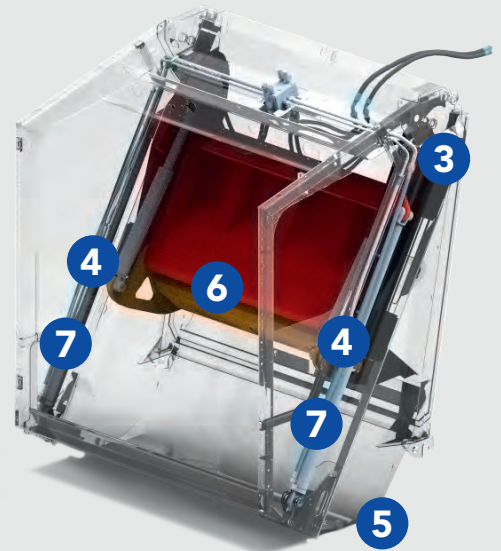
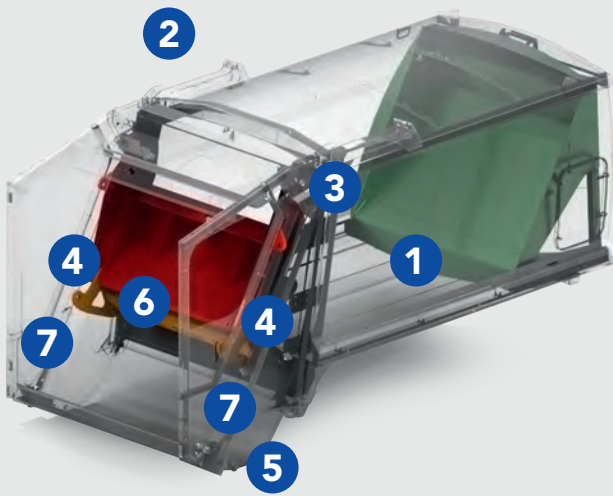

1 Leachate tank at the bottom of the body. Keel shaped floor helps leachate flow to drain sump.

2 Tailgate lift cylinders on the hopper roof

3 Full height tailgate seal

4 External cylinders

5 Minimum overhang

6 High absorption capacity press

7 2 grease points

CHOOSING A TERBERG BIN LIFT SYSTEM FOR YOUR OLYMPUS ART

The bin lift systems detailed here represent a small selection of what we offer.

Bin lift systems are at the heart of what our dedicated Terberg Machines manufacturing centre does. We've been manufacturing and supplying bin lift innovations since the introduction of wheelie bin back in the 1980's. From our very first basic prototype system all the way through to the latest front line, fully automatic, low voltage, electric OmniDEL (E) lift today.

With models ranging from simple hydraulic systems to the most advanced fully automatic electric solutions, we also offer an accompanying range of dynamic weighing and identification systems.

In 2020, the number of manufactured lift systems surpassed an amazing 25,000 and our systems are used to collect municipal and industrial waste, with models offering a low or high rava rail, electric or hydraulic power options, body-integrated or frame-mounted, manual, semi-automatic and fully automatic operation.

Our extensive expertise and customer focus means that we will have a system available to meet your exact requirement.



TGV ART

The TGV ART is Terberg's heavy duty, large volume container lifting solution, ideally suited to the collection of large volumes of all types of waste and recyclable materials.

The TGV ART lifts 2-wheel domestic and 4-wheel commercial containers ranging from 120 to 4500 litre capacity.

FEATURES OF OLYMPUS ART

Specially developed for global markets where EN compliance is not required

Low cost and easy maintenance as standard

Capacities ranging from 10 to 27m³

The Olympus ART range of refuse collection bodies offers a selection of narrow and wide variants

Specially designed for domestic and commercial waste streams

Large hopper resulting in reduced compaction cycles

The Olympus ART comes with an automatic packing cycle

Optimum hydraulic performance at low engine speed-less fuel and less heat

Optional in-cab control system for body discharge and compaction mechanisms

Manual hydraulic control system for body discharge and compaction mechanism by means of levers

Large selection of integrated and DIN mounted bin lifter systems

A High Capacity Tailgate (HCT) is also available - better suited to the compaction of bulky waste and

the emptying of larger volume containers more than 2m³ such as skips and underground systems with cranes.

PLC computer delivers reliability and better control

Optional CE/EN1501 features available such as footboards and CCTV systems

Terberg Connect option to enable bi-directional remote diagnostics

Optional in-cab 7" control monitor



OmniGV ART

Multipurpose, Large Volume Bin Lift system. With a robust design perfect for handling household and industrial waste in most harsh environments.

OmniGV ART is able to accept hand loading as well as a wide range of containers from 120 Liter wheelie bins up to 5 to 10 cubic meter DIN30720 Skip containers using 4 chains. as well as accepting hand loading. The innovative design allows a lifting of 7 Tons on a RCV.

OmniTRADE-B ART

Available in both 2.2m or 2.5m wide, OmniTRADE-B ART is available with a host of optional features to give you a trade bin lift with superb functionality and flexibility that allow you to deliver efficient collection rounds. In standard trim, the OmniTRADE-B ART is operated by a simple, yet effective, hydraulic lever and comes complete with DIN pick up arms to enable handling of 1100 litre 4-wheel containers with trunnions. Maintenance and whole life costs are kept to a minimum through the use of low maintenance bearings and stainless steel axles.

OmniDEL ART

The ultimate fully automatic bin lift system got global markets outside the EEA. OmniDEL ART is a low level, split, fully automatic bin lift, specifically designed for operating in harsher environments around the world.

OmniDEL ART offers high speed, robust build, safe operation and minimal maintenance synonymous with the Terberg brand.

OmniDEL ART is light, DIN frame mounted and customisable, it can also be optimised with Terberg weighing and RFID systems.

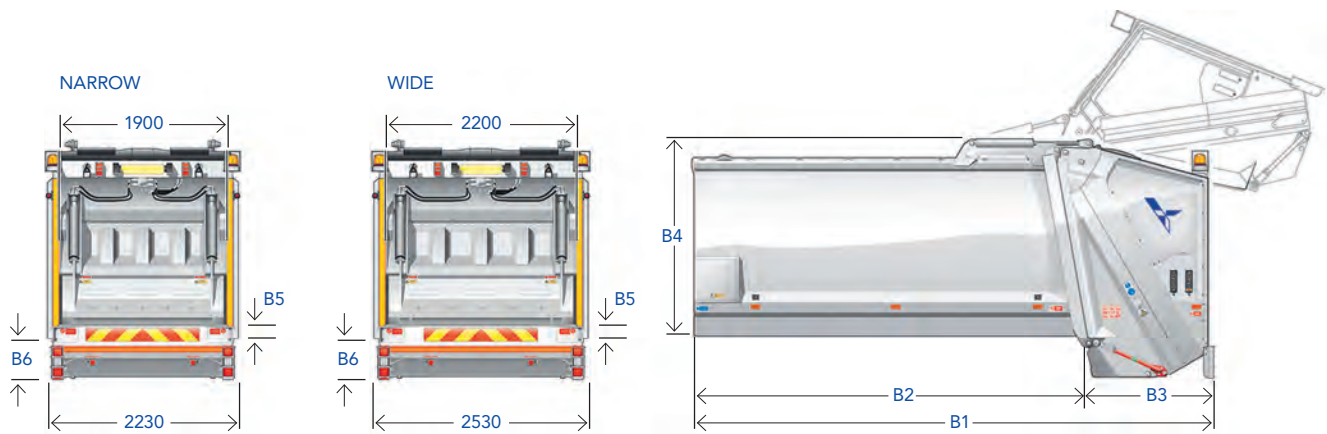

MODEL		OLNM-13W	OLNM-16W	OLNM-17W	OLNM-19W	OLNM-20W	OLNM-21W	OLNM-23W	OLNM-25W	OLNM-27W
GVW chassis (t) (1)		16	18-19	18-19	26	26	26	26	26	32
Recommended Wheelbase: 1st to 2nd axle (Approx. mm)		3400-3500	3800-3900	4100-4200	3300-3400	3500-3600	3800-4000	4100-4200	4500-4600	(3)
Useful body capacity (m ³)		13,0	15,6	16,6	18,6	20,0	21,4	23,2	25,6	26,5
Body Weight (Open Back) (kg)		5135	5328	5409	5591	5697	5802	5942	6146	6216
Overall Length (mm)	B1	4975	5525	5725	6175	6475	6775	7175	7675	7875
Overall Length-Tailgate raised (mm)	B1	6053	6603	6803	7253	7553	7853	8253	8753	8953
Body Floor Length (mm)	B2	3460	4010	4210	4660	4960	5260	5660	6160	6360
Tailgate floor Length (mm)	B3					1515				
Body Height including sub-frame (mm) (2)	B4					2490				
Underside of tailgate relative to chassis height (mm) (2)	B6					-472				
Maximum external Width (mm)						2530				
Tailgate internal width without lifter (mm)						2200				
Compaction mechanism cycle time (s)						18				
Absorption speed (m ³ /min)						5,2				

MODEL		OLNM-10N	OLNM-11N	OLNM-12N	OLNM-14N	OLNM-16N	OLNM-19N
GVW chassis (t) (1)		16	16	16	18-19	18-19	26
Recommended Wheelbase: 1st to 2nd axle (Approx. mm)		3100-3200	3400-3500	3700-3800	3800-3900	4500-4600	3800-4000
Useful body capacity (m ³)		10,3	11,3	12,5	13,6	16,0	18,6
Body Weight (Open Back) (kg)		4817	4899	5003	5082	5371	5533
Overall Length (mm)	B1	4725	4975	5275	5525	6175	6775
Overall Length-Tailgate raised (mm)	B1	5803	6053	6353	6603	7253	7853
Body Floor Length (mm)	B2	3210	3460	3760	4010	4660	5260
Tailgate floor Length (mm)	B3					1515	
Body Height including sub-frame (mm) (2)	B4					2490	
Underside of tailgate relative to chassis height (mm) (2)	B6					-472	
Maximum external Width (mm)						2230	
Tailgate internal width without lifter (mm)						1900	
Compaction mechanism cycle time (s)						18	
Absorption speed (m ³ /min)						4,6	

NOTE: This document and the information or advice given to the customer is merely for guidance and does not constitute any contractual obligation. Nor can any obligation, guarantees or responsibility be taken from it on the part of the company.

All specifications are subject to manufacturers tolerances. An allowance of +/- 2% should be made for all weights. Additional equipment may alter dimensions and weights quoted.

(1) Subject to legislation in territory.

(2) Height profile sub-frame 115 mm.

(3) 4-axle chassis configuration (8x4) to consult.

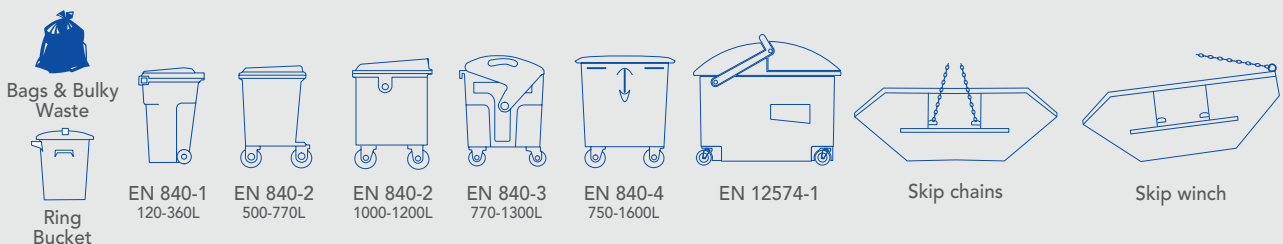



- TE headquarters, IJsselstein (NL)
- Production, Sales & Service subsidiaries
- Sales and Service subsidiaries
- Authorised distributors
- Direct Sales

MANUFACTURING CENTRES

ROSROCA SA
Tàrrega, Spain

TERBERG ROSROCA VEHICLE MANUFACTURING LLC.
Dubai, United Arab Emirates

TERBERG ZENITH
Singapore

DENNIS EAGLE Ltd.
Warwick, UK

TERBERG MACHINES BV
IJsselstein, The Netherlands

TERBERG ZENITH MALAYSIA
Selangor, Malaysia

AUTHORISED DISTRIBUTORS FOR OLYMPUS ART

MIDDLE EAST

GCC

Terberg RosRoca Vehicle
Manufacturing LLC
Dubai
terbergrosrocavm.ae

Malaysia

Terberg Zenith Malaysia
Balakong 43300
terbergzenith.com.my

Singapore

Terberg Zenith
Singapore 629528
terbergzenith.com.sg

EAST ASIA

Hong Kong

MAN Truck & Bus Hong Kong Ltd
8520 Hong Kong

Philippines

Bowman Technologies Inc
Manila

Vietnam

Tien Ngoc Company
Thoi An Ward
tienngoc.com.vn



TERBERG ENVIRONMENTAL

Postbus 202, 3400 AE IJsselstein, The Netherlands

T +31 (0)30 68 68 700, E sales@terbergenvironmental.com, I www.terbergenvironmental.com

We reserve the right to carry out technical modifications. Modification of specifications may be carried out without prior notice. Illustrations may not necessarily depict current equipment versions.